

ELMO

CCD Color Camera Head

Operation Manual

MODEL

UN43H

INFORMATION

This equipment has been tested and found to comply with the limits for a Class A digital device, pursuant to Part 15 of the FCC Rules. These limits are designed to provide reasonable protection against harmful interference when the equipment is operated in a commercial environment. This equipment generates, uses, and can radiate radio frequency energy and, if not installed and used in accordance with the instruction manual, may cause harmful interference to radio communications. Operation of this equipment in a residential area is likely to cause harmful interference in which case the user will be required to correct the interference at his own expense.

USER-INSTALLER CAUTION: Your authority to operate this FCC verified equipment could be voided if you make changes or modifications not expressly approved by the party responsible for compliance to Part 15 of the FCC rules.

This Class A digital apparatus complies with Canadian ICES-003.

Cet appareil numérique de la classe A est conforme à la norme NMB-003 du Canada.

CAUTIONS ON USE

- Please use this apparatus by connecting only with camera control unit Elmo CC431E.
- Read the "CAUTIONS ON USE AND INSTALLATION" in the operation manual of CC431E, and follow them.

COMPONENTS

- (1) Camera head (without lens) 1
- (2) Accessories
 - (a) Camera holder 1
 - (b) Operation manual 1

CONNECTION

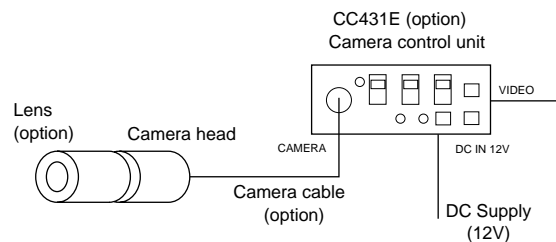

● When connecting or disconnecting the camera cables (for the camera head and camera control unit), always turn off the power switch of the camera control unit first. If not, the camera head may be damaged.

DISCLAIMER

We disclaim any responsibility and shall be held harmless for any damages or losses incurred by the user in any of the following cases:

1. Fire, earthquake or any other act of God; acts by third parties; misuse by the user, whether intentional or accidental; use under extreme operating conditions.
2. Malfunction or non-function resulting in indirect, additional or consequential damages, including but not limited to loss of expected income and suspension of business activities.
3. Incorrect use not in compliance with instructions in this instruction manual.
4. Malfunctions resulting from misconnection to other equipment.
5. Repairs or modifications made by the user or caused to be made by the user and carried out by an unauthorized third party.
6. Notwithstanding the foregoing, ELMO's liabilities shall not, in any circumstances, exceed the purchase price of the product.

COPYRIGHT AND RIGHT OF PORTRAIT

There may be a conflict with the Copyright Law and other laws when a customer uses, displays, distributes, or exhibits an image picked up by a television camera without permission from the copyright holder. Please also note that transfer of an image or file covered by copyright is restricted to use within the scope permitted by the Copyright Law.

CAUTIONS ON USE AND INSTALLATION

- Carefully handle the units. Do not drop, or give a strong shock or vibration to the camera. This may cause problems. Treat the camera cables carefully to prevent cable problems, such as cable breakdown and loosened connections.
- Do not shoot intense light. If there is an intense light at a location on the screen such as a spot light, a blooming and smearing may occur. When intense light enters, vertical stripes may appear on the screen. This is not a malfunction. Ghosts may occur when there is an intense light near the object. In this case, change the shooting angle.
- Install the camera in a location free from noise. If the camera or the cables are located near power utility lines or a TV, etc. undesirable noise may appear on the screen. In such a case, try to change the location of the camera or the cable wiring.
- Moire
When thin stripe patterns are shot, stripe patterns that are not actually there (moire) may appear as interference stripes. This is not a malfunction.
- Operating ambient temperature and humidity. Do not use the camera in places where temperature and humidity exceed the specifications. Picture quality will lower and internal parts may be damaged. Be particularly careful when using in places exposed to direct sunlight. When shooting in hot places, depending on the conditions of the object and the camera (for example when the gain is increased), noise in the form of vertical strips or white dots may occur. This is not a malfunction.
- Handling of the protection cap. Keep the protection cap away from children. Children may put them into mouth or swallow them accidentally. The protection cap protects the image sensing plane when the lens is removed from the camera, do not throw away.
- When not using the camera for a longtime. Stop supplying power.
- When cleaning the camera
Always turn off the power and clean with a piece of soft dry cloth. Do not use benzene, alcohol, thinner, household detergents, chemically treated cloths, etc. If used, coating and printed letters may be discolored. When cleaning the lens, use a lens cleaning paper, etc.
- Avoid using or storing the camera in the following places:
Places filled with highly flammable gas.
Places near gasoline, benzene, or paint thinner.
Places subject to strong vibration.
Places contacting chemicals (such as pesticides), rubber or vinyl products for a long period of time.

SPECIFICATIONS

Image sensor	1/3 inch IT-CCD
Effective pixels	Horizontal: 768 pixels, Vertical: 494 pixels
Effective image area	Horizontal: 4.88 mm, Vertical: 3.66 mm
Resolution	Horizontal: More than 470 lines, Vertical: More than 350 lines
Standard intensity of illumination for objects	40 lx (F1.6, 3000K)
Minimum intensity of illumination for objects	3.5 lx (F1.6, 3000K)
Weight	0.32 oz (9g)

- Design and specifications are subject to change without notice.

OPTIONAL PARTS

For further details, contact your Elmo dealer.

Camera control unit

Type name
CC431E

Camera cable

Type	Code #	Nominal length	Diameter
EMC-02H	9833	2m	5.0mm
EMC-03H	9833-1	3m	5.0mm
EMC-05H	9833-2	5m	5.0mm
EMC-12H	9833-3	12m	5.0mm
EMC-20H	9833-4	20m	5.0mm
EMC-30H	9833-5	30m	5.0mm

Miniature lens

Type	Code #	Nominal length	Diameter
TT203	9289	f=3mm	2.0
TT1655	9283	f=5.5mm	1.6
TT2011	9288	f=11mm	2.0
TT3318	9295	f=18mm	3.3

Macro lens

Type	Code #	Focal length	Magnifications
TT426MA	9800	f=26mm	X0.25-X0.4
TT426MB	9801	f=26mm	X0.4-X0.7
TT426MC	9802	f=26mm	X0.7-X1

*EMC-54H is not applicable for this model.

EXTERIOR DIMENSIONS

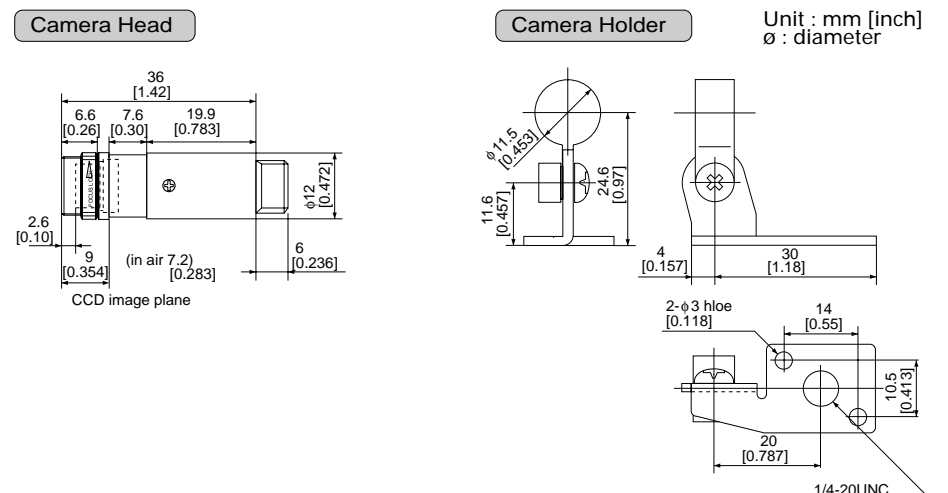

ELMO® ELMO CO., LTD.

6-14, Meizen-cho, Mizuho-ku, Nagoya, 467-8567 Japan

OVERSEAS SUBSIDIARY COMPANIES

ELMO Mfg. Corp.

1478 Old Country Road,
Plainview, NY 11803-5034
U.S.A.
Tel. 516-501-1400
Fax. 516-501-0429
E-mail: elmo@elmousa.com
Web: http://www.elmoussa.com

ELMO Canada Mfg. Corp.

44 West Drive, Brampton,
Ontario, L6T 3T6,
Canada
Tel. 905-453-7880
Fax. 905-453-2391
E-mail: info@elmocanada.com
Web: http://www.elmocanada.com

ELMO (Europe) G.m.b.H.

Neanderstr. 18
40233 Düsseldorf,
Germany
Tel. 0211-376051-53
Fax. 0211-376630
E-mail: elmo@elmo.eu
Web: http://www.elmo.de

ELMO and ELMO are registered trademarks of ELMO COMPANY, LIMITED.