

ELMO

PAN • TILT • ZOOM COLOR CAMERA

PTC-400C



INSTRUCTION MANUAL

Please read this instruction manual carefully before using this PTC-400C and keep it for future reference.

IMPORTANT SAFETY INSTRUCTIONS

1. Read these instructions.
2. Keep these instructions.
3. Heed all warnings.
4. Follow all instructions.
5. Do not use this apparatus outdoors.
6. Do not use this apparatus near water.
7. Clean only with dry cloth.
8. Do not install near heat sources such as radiators, heat registers, stoves or other apparatus (including amplifiers) that produce heat.
9. Do not touch this apparatus during lightning storms.
10. Unplug when unused for long periods of time.
11. Refer all servicing to qualified personnel. Servicing is required when the apparatus has been damaged in any way, such as power-supply cord or plug is damaged, liquid has been spilled or objects have been fallen onto the apparatus, the apparatus has been exposed to rain or moisture, does not operate normally, or has been dropped.

WARNING: Handling the cord on this product or cords associated with accessories sold with this product, will expose you to lead, a chemical known to the State of California to cause birth defects or other reproductive harm.
Wash hands after handling.

	CAUTION RISK OF ELECTRIC SHOCK DO NOT OPEN	
<p>CAUTION : TO REDUCE THE RISK OF ELECTRIC SHOCK. DO NOT REMOVE COVER (OR BACK). NO USER SERVICEABLE PARTS INSIDE. REFER SERVICING TO QUALIFIED SERVICE PERSONNEL.</p>		

 The lightning flash with arrowhead symbol, within an equilateral triangle, is intended to alert the user to the presence of uninsulated "dangerous voltage" within the product's enclosure that may be of sufficient magnitude to constitute a risk of electric shock to persons.

 The exclamation point within an equilateral triangle is intended to alert the user to the presence of important operating and maintenance (servicing) instructions in the literature accompanying the appliance.

CAUTION

- Do not use any power supply other than specified.

WARNING

TO REDUCE THE RISK OF FIRE OR ELECTRIC SHOCK, DO NOT EXPOSE THIS APPLIANCE TO RAIN OR MOISTURE.

- * The CAUTION label is attached on the base of product.

INFORMATION

This equipment has been tested and found to comply with the limits for Class B digital device, pursuant to Part 15 of the FCC Rules. These limits are designed to provide reasonable protection against harmful interference when the equipment is operated in a commercial environment.

This equipment generates, use, and can radiate radio frequency energy and, if not installed and used in accordance with the instruction manual, may cause harmful interference to radio communications. Operation of this equipment in a residential area is likely to cause harmful interference in which case the user will be required to correct the interference at his own expense.

USER-INSTALLER

CAUTION: Your authority to operate this FCC verified equipment could be voided if you make changes or modifications not expressly approved by the party responsible for compliance to Part of the FCC Rules.

HANDLING PRECAUTIONS

- This Camera has no power switch. When checking and maintaining this Camera, be sure to turn OFF the power supply to the main unit beforehand.
- This Camera is designed only for use indoors. Do not use this Camera out of doors.
- Do not leave the Camera under direct sunlight or by heater, or the Camera may be discolored, or damaged.
- Do not place the Camera in any humid, dusty, windy or vibrating location. Use the Camera in the following environmental condition:
 - Temperature: -10 °C ~ 40 °C (14 ° ~ 104 °F)
 - Humidity: 30% ~ 90% (No condensation)
- Use a soft, dry cloth for cleaning. Do not use any volatile solvent, such as thinner or benzine.
- Do not directly point the camera lens into the sun, or the camera may be damaged.
- Caring for the batteries:
 - If the Camera is not used for long time, take out the batteries from the case.
 - Do not use rechargeable Ni-Cd batteries.
 - Do not use new and old batteries, or batteries of different type together.
 - Do not try to recharge or short-circuit the batteries.
- This Camera is designed only for installation to the ceiling.
When installing this Camera, use only the dedicated fixing plate, refer to the pages 9 to 13 of this manual, and carefully check the safety, such as falling prevention.

CONTENTS

IMPORTANT SAFETY INSTRUCTIONS	1
HANDLING PRECAUTIONS	3
1. PART NAMES AND FUNCTIONS.....	5
2. WIRELESS REMOTE CONTROLLER	7
3. SETTING UP	9
4. OPERATION PROCEDURES	14
[1] Power supply to the Camera	14
[2] Turning ON/OFF of the Camera power	14
[3] Operating PAN/TILT	15
[4] Lens operation	15
[5] Preset operation	17
[6] External unit control	18
5. THE ID NUMBER (REMOTE ID) SETTING	19
6. SETTING IN THE OSD (ON-SCREEN DISPLAY) MENU.....	20
7. SETTING OF ALARM IN-OUT	28
[1] Alarm input	28
[2] Alarm output	28
8. SETTING OF RS-485	29
[1] Setting the terminating resistance	29
[2] Setting the ID address	29
9. SETTING OF VARIOUS MODES.....	30
[1] Initializing the settings	30
10. TROUBLESHOOTING HINTS.....	31
11. SPECIFICATIONS.....	33
12 SUPPLIED ACCESSORIES.....	35
13 OPTIONS	36

1. PART NAMES AND FUNCTIONS

● Main unit

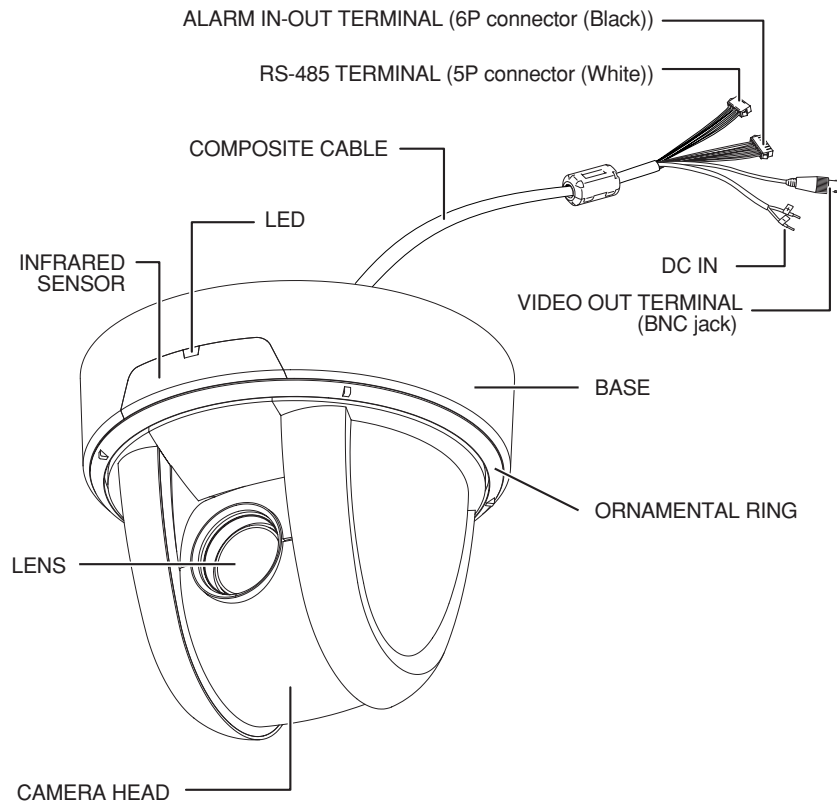

● Wireless Remote Controller

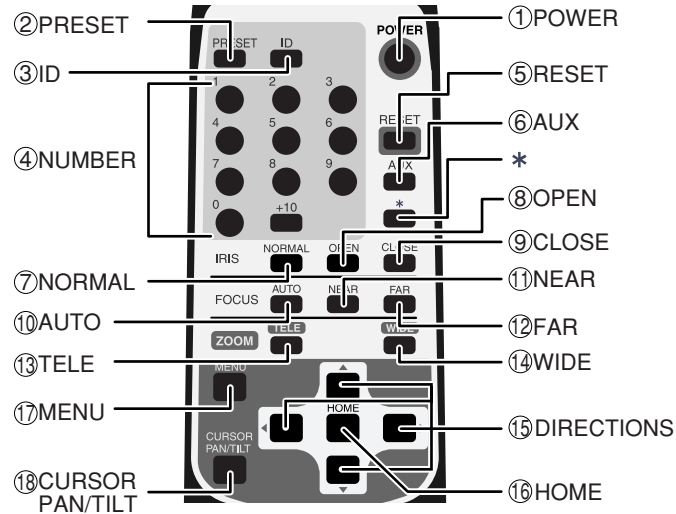

Note: The “*” button is not used for normal operation.

Button Name	Function	Ref. Page
① POWER	To turn ON/OFF the Camera power.	P.14
② PRESET	To register the preset position.	P.17
③ ID	To set the ID No. when multiple Cameras are used.	P.19
④ NUMBER	To set the preset position and the ID No.	P.17
⑤ RESET	To readjust the position of the Camera head.	P.15
⑥ AUX	Alarm signal is outputted from ALARM OUT terminal (2). Prior setting of the OSD mode is required.	P.18
⑦	NORMAL To return the iris to the factory setting automatically.	P.16
⑧ IRIS	OPEN To open the iris.	P.16
⑨	CLOSE To close the iris.	P.16
⑩	AUTO To adjust the focal point automatically to maintain it in the “in focus” status.	P.16
⑪ FOCUS	NEAR To move the focal point near.	P.16
⑫	FAR To move the focal point far.	P.16
⑬	TELE To zoom in (TELE) the image.	P.15
⑭ ZOOM	WIDE To zoom in (WIDE) the image.	P.15
⑮ DIRECTIONS	To change the Camera head direction by operating the cursor on the OSD.	P.15, 20
⑯ HOME	To move the Camera head direction by operating the cursor on the OSD.	P.15, 20
⑰ MENU	To turn ON/OFF the OSD display. In the hierarchical menu, the screen immediately before appears.	P.19, 20
⑱ CURSOR PAN/TILT	To suspend the menu operation.	P.20

2. WIRELESS REMOTE CONTROLLER

Point the infrared emitter of the wireless remote controller to the infrared sensor located on the front of the Camera main unit, and press the button of the intended operation.

For the receivable range, refer to the below figures.

● Receivable range

Distance : Within approx. 7m from the infrared sensor front

Angle : Within approx. 60° right and left, approx. 10° above and approx 30° below from the infrared sensor front

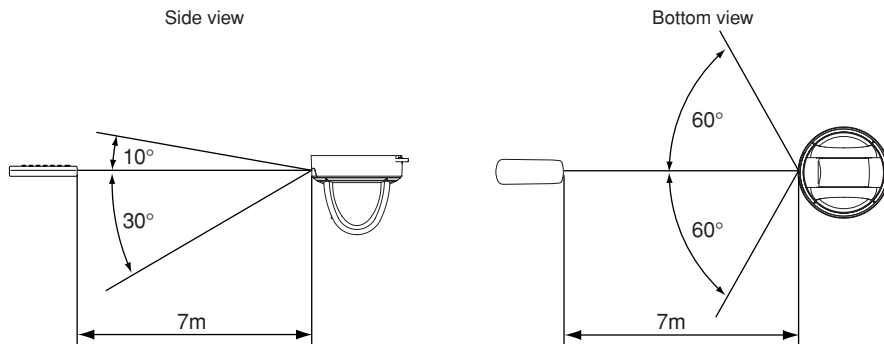

Note: The infrared sensors may receive the infrared rays only within a narrower receivable range or may not receive them at all depending on the ambient environment, such as being placed under the sunlight or near an inverter fluorescent lamp. In such case, relocate the installation place of the receiving side or block off the sunlight.

● Precaution for the battery

Remove the battery case cover by pressing downward on the [▼] mark part in the direction as indicated by the arrow.

Install 2 pcs. of batteries (type R03,AAA) into the case in the direction as indicated there.

Note: Install the batteries with the proper ⊕ to ⊕ and ⊖ to ⊖ polarity.

Note: For dry cells, be sure to use the size AAA.

Note: Change the batteries at least once a year or when even necessary.

Note: The supplied batteries supplied with the Camera are only for use in initially confirming the operation of the Camera.

It is not guaranteed that these batteries will work effectively for the indicated period.

- When multiple Cameras are operated through the wireless remote controller

Refer to "5. THE ID NUMBER SETTING" on P. 19.

3. SETTING UP

[1] Installation

Note: When carrying the Camera, be sure to hold the base.

Note: Do not turn the Camera head in the PAN-TILT direction by hand, or the Camera head could be broken.

(1) Mounting the Fixing Plate

1. Make mounting holes and a cord hole in the place (ceiling) to which this Camera is installed.

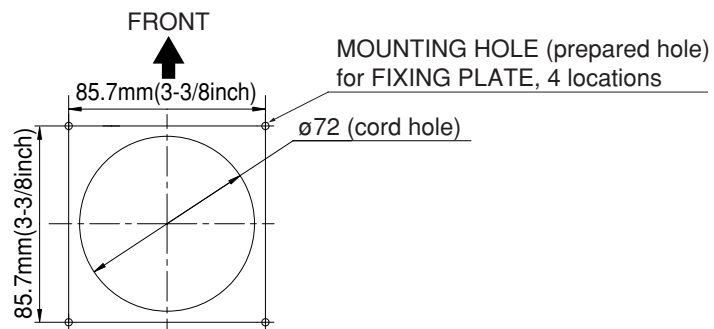

WARNING: The total mass of the main unit and fixing plate is approx. 900g. Check whether the ceiling to which the Camera is installed is strong enough to hold the total mass of the main unit and fixing plate. If not, the Camera could fall, causing injury.

2. Lock the fixing plate (supplied) firmly with 4 fixing screws (not supplied).

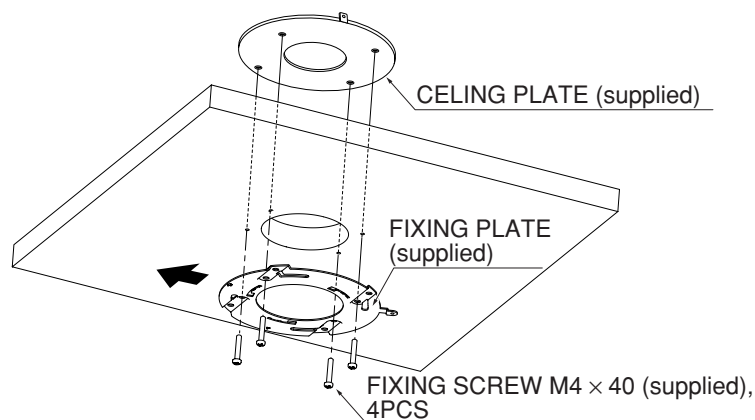

WARNING:Fasten the fixing screws of the fixing plate firmly, or the Camera could fall, causing injury.

(2) Mounting the Camera to the Fixing Plate

1. Match the [△] mark on the fixing plate with the [△] mark on the back face of the main unit, set the tabs (3 locations) of the back face of the main unit in the mating cuts (3 locations) of the fixing plate, and turn the main unit clockwise by 25° (Refer to A)

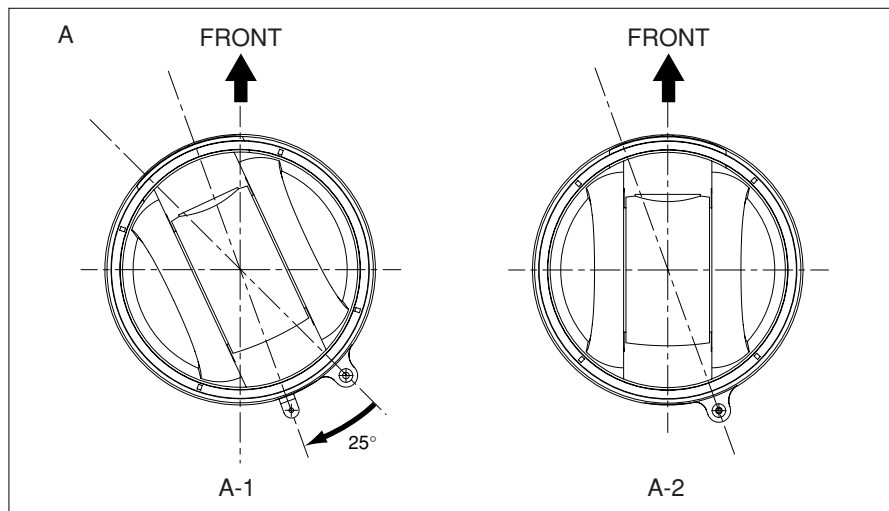
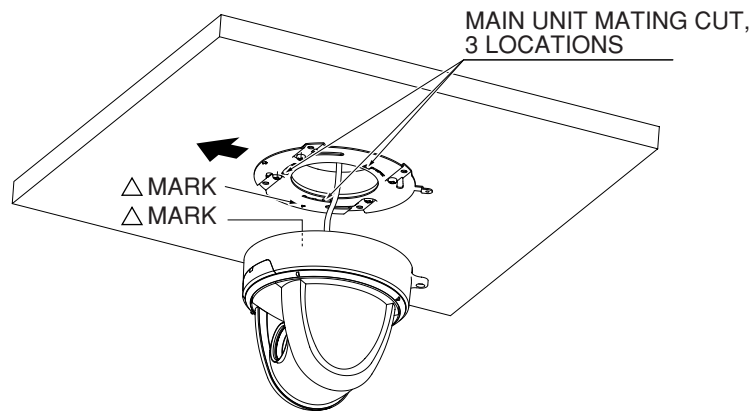

(3) Mounting the Safety Wires

1. Loop up one end of the Safety Wires through the respective safety wire looping holes made on the Ceiling Plate, and then loop up the other end of the same around the beams or anything that is used to mount ceiling tile channel for structure safety.

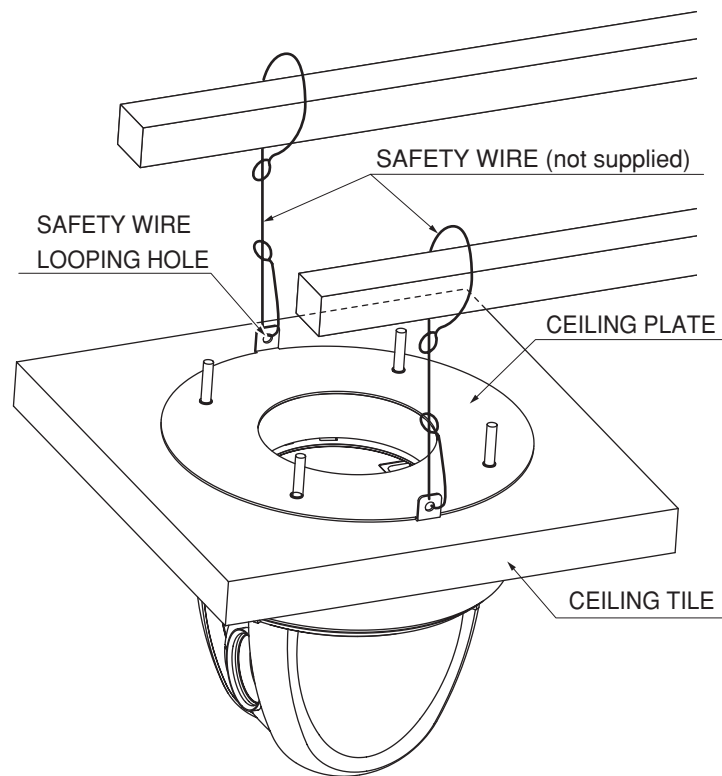

2.Lock the Camera and the fixing plate with the set screws (supplied).

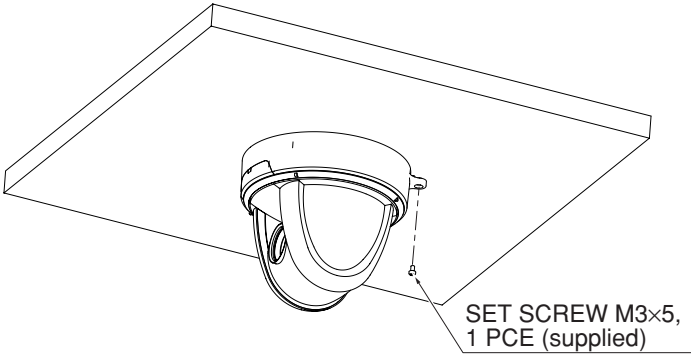

[2] Drawing the Composite Cable from the Camera Back Face

(1) Cut off the blank cover from the back face of the Camera base with pliers or the like, and draw the composite cable from the back face of the Camera.

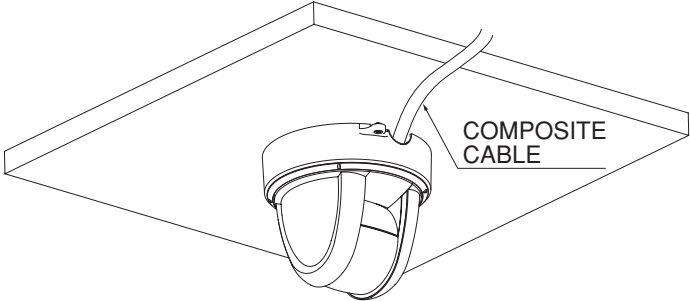
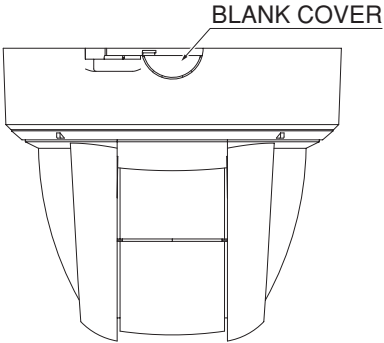

● Connection of the Camera

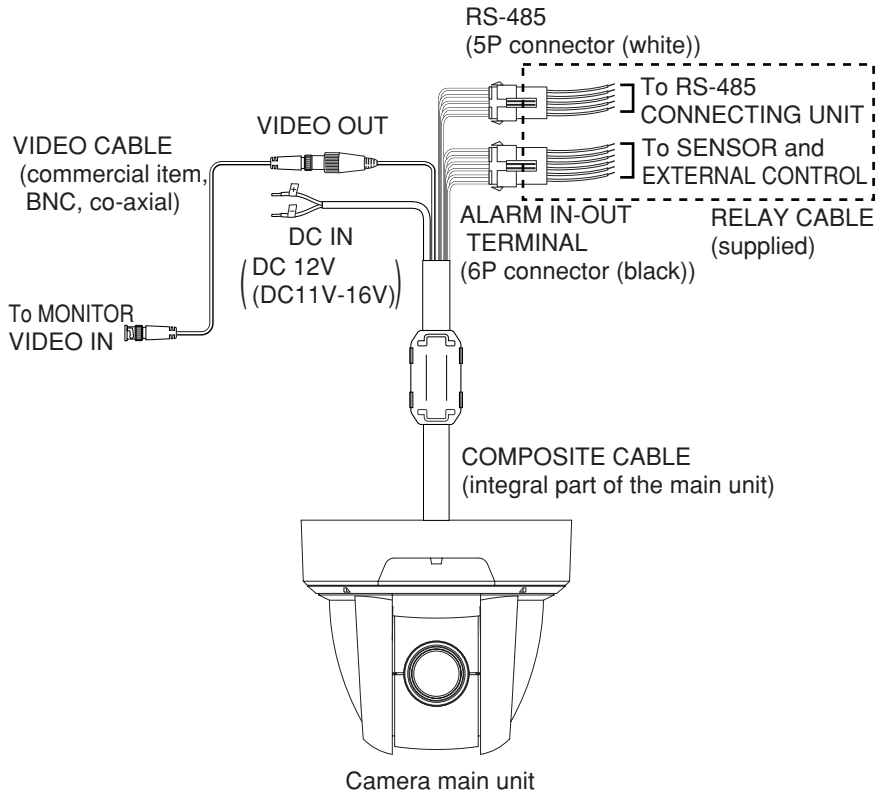

RS-485 terminal
(5P connector (white))

Pin No.	Terminal Name	Cord Color
①	DATA (+) IN	Brown
②	DATA (-) IN	Red
③	DATA (+) OUT	Orange
④	DATA (-) OUT	Yellow
⑤	GND	Green

ALARM IN-OUT terminal
(6P connector (black))

Pin No.	Terminal Name	Cord Color
①	ALARM IN1	Blue
②	GND	Purple
③	ALARM IN2	Gray
④	GND	White
⑤	ALARM OUT1	Black
⑥	ALARM OUT2	Pink

Note: When wiring, note the following:

- For the RS-485 ALARM IN-OUT cable, insulate the bare conductor part not to be exposed after wiring.
- For the video cable, keep the BNC connector (metal part) away from any other metal material.

4. OPERATION PROCEDURES

[1] Power supply to the Camera

The Camera has no POWER switch. The power supply to the Camera is turned ON when 12VDC is inputted to the DC IN terminal.

When power is supplied to the Camera, the Camera turns to the right and then to the center automatically (viewed from the front), returning the Camera position to the position set in advance.

[2] Turning ON/OFF of the Camera power

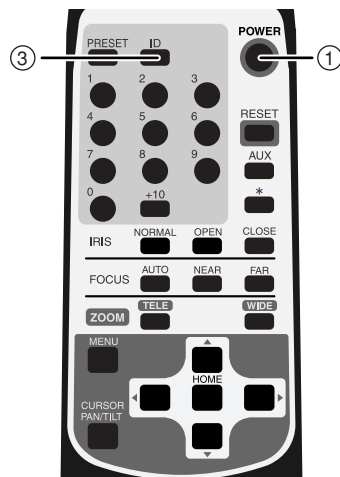

(1) Turning OFF the Camera

- When the Camera is ready for operation through the wireless remote controller and ① **POWER** button is pressed, the Camera power is turned OFF. (However, even after the Camera is turned OFF, power is still being supplied to the Camera as power supply to the Camera is not OFF.)
- The image disappears, and the LED on the Camera lights up in red. Now, no buttons on the wireless remote controller are functional other than ① **POWER** button and ③ **ID** button.
- When the TIMER OFF function is ON (refer to the settings in the OSD (On-Screen Display) Menu screen on P.21), Camera power is turned OFF automatically upon the lapse of the set time.

(2) Turning ON the Camera

- When the Camera is OFF and ① **POWER** button is pressed, the Camera power is turned ON.
- The image appears, and the LED on the Camera goes out. Now, the Camera is ready for operation of all functions through the wireless remote controller.
- If the ID number is changed, the Camera power may not be turned ON. In such case, redo the ID number setting, and press ① **POWER** button.

[3] Operating PAN/TILT

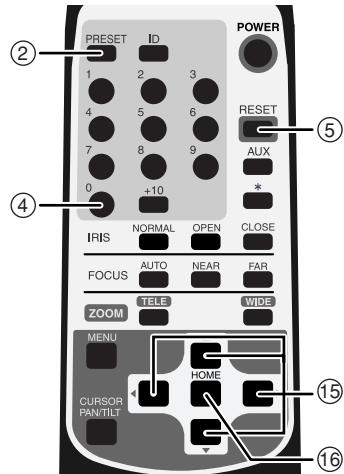

- While watching the screen, press any of ⑮ (UP, DOWN, LEFT, RIGHT) direction buttons for the direction in which you want to watch the image.
- To change the direction minutely, jog the direction button. To change the direction largely, hold down the direction button.
- Two operation modes are available according to the speed: AUTO mode changing the speed according to the zoom position, and MANUAL mode setting the speed manually. (Refer to the settings in the OSD (On-Screen Display) Menu screen on P.26)

- When ⑯ **HOME** button is pressed, the Camera turns to the front (and the lens moves to the WIDE end) according to the factory settings. The home position can be set freely with the preset No. "0." (Press ② **PRESET** button and then press ④ **0** button.) After setting, when ④ **0** button or ⑯ **HOME** button is pressed, the home position is loaded. (Refer to P. 17)
- If the Camera direction is changed manually by mistake, press ⑤ **RESET** button. Then, the Camera remembers the last PAN/TILT position in memory.

[4] Lens operation

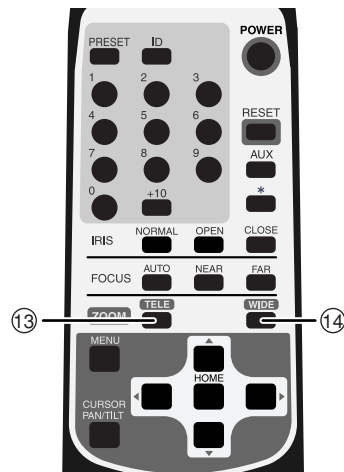

(1) Zoom operation

- The object is zoomed in (appears larger in the screen) when ⑬ **TELE** button of ZOOM is pressed, or zoomed out (appears smaller in the screen) when ⑭ **WIDE** button of ZOOM is pressed.
- When ⑬ **TELE** button or ⑭ **WIDE** button is held down for over one second, the zoom speed increases.

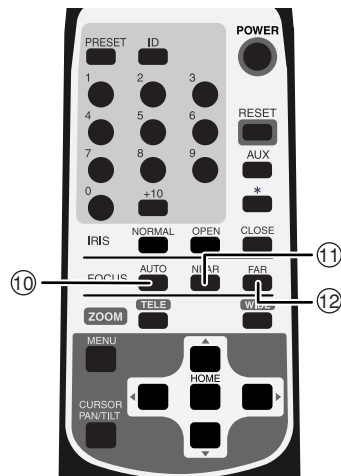

(2) Focus operation

- When ⑩ **AUTO** button of FOCUS is pressed, the FULL AUTO FOCUS status is established. However, focusing may be difficult for such objects as listed below.
 - Objects with no contrast between light and shade, such as white walls and night views
 - Objects reflecting an intensive light
 - Objects moving fast
 - Objects with many horizontal stripes, such as blinds
 - Objects with vertical fine stripes.
 - Objects viewed through a glass pane with water drops or stains
 - Dark objects
- To adjust the focus manually, press ⑪ **NEAR** button or ⑫ **FAR** button.

When ⑪ **NEAR** button is pressed, the focus shifts near to you.

When ⑫ **FAR** button is pressed, the focus shifts far away from you.

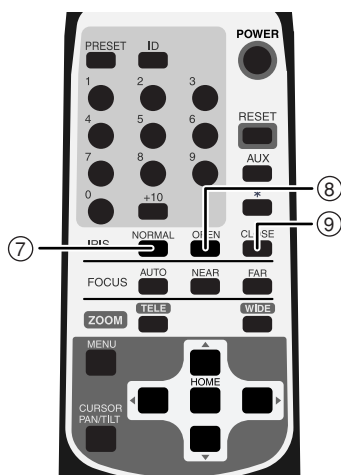

(3) Iris

- The iris remains in the AUTO IRIS status (in the Auto Control mode in which the brightness remains unchanged even if the object is changed).
- When ⑧ **OPEN** button or ⑨ **CLOSE** button of the iris is pressed, the brightness changes in the AUTO IRIS status. (The reference level of the AUTO IRIS changes.)
- ⑧ **OPEN** button or ⑨ **CLOSE** button cannot be held down. To operate the iris continuously, repeat pressing and releasing the button.
- When ⑦ **NORMAL** button is pressed (in the AUTO IRIS state), the brightness is reset to the standard level.

[5] Preset operation

The Camera head direction, the zoom position, the focus status and the brightness status can be registered. In addition to these items, when [MAIN CONTROL] – [CAMERA2 PRESET] is set to [ON] in the OSD menu, the [CAMERA2] settings can also be registered together (Refer to P. 23). Up to 17 setting can be registered (Nos. 0 – 16). Even if the main unit power is turned OFF, the registered contents are preserved.

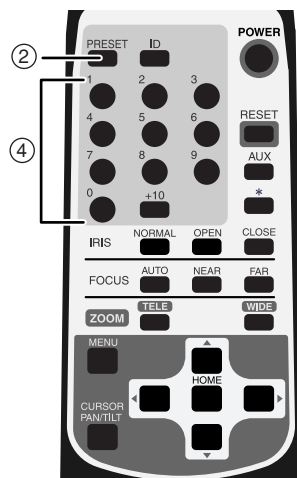

(1) Registration in the Preset Contents

- Set the Camera head direction, the zoom position, the focus status and the brightness level. (To register the [CAMERA2] settings together, set [MAIN CONTROL] – [CAMERA2 PRESET] to [ON] in the OSD menu.)
- When ② [PRESET] button is pressed (once), the LED (light emitting diode) on the main unit blinks in green (at intervals of 0.2 sec). To cancel this step, press ② [PRESET] button again.
- Then, input the preset No. within 0 through 16 by pressing ④ corresponding one or two of the 0 through +10 buttons. (+10 button is used to input numeric of 10 or larger. For “10,” press +10 button and then 0 button.)
- Upon pressing, the LED on the main unit goes out and the registration of the preset contents is completed. (The preset contents already registered, if any, are overwritten.)
- The home position can be registered freely to any position by using the preset No. “0.”

(2) Execution of the Preset

- When ④ intended one or two of the 0 through +10 buttons is pressed, the Camera head direction, the zoom position, the focus status and the brightness level are set as per registered. (+10 button is used to input numeric of 10 or larger. For “10,” press +10 button and then 0 button.)

[6] External unit control

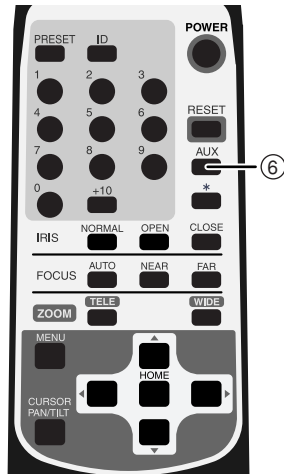

To make ⑥ **AUX** button functional, set [ALARM] – [ALARM OUT2] to [ON] in the OSD menu beforehand.

When ⑥ **AUX** button is pressed, the external unit connected to the ALARM OUT terminal <2> is turned ON. To turn it OFF, press ⑥ **AUX** button again.

5. THE ID NUMBER (REMOTE ID) SETTING

When multiple Cameras are laid out adjacently and operated via the wireless remote controller, the Cameras receiving the infrared rays operates in unison in the same way. When each Camera is allocated with a different ID No., the Camera can be operated selectively when its ID No. is specified via the wireless remote controller. The ID Nos. can be allocated to up to 9 Cameras.

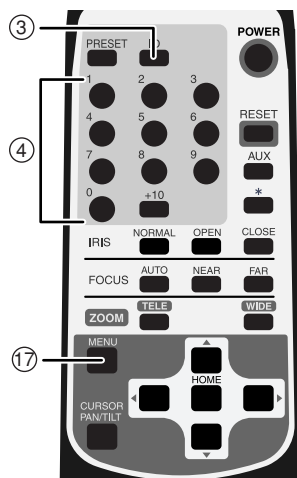

(1) Setting an ID No.

- Turn ON only the camera to be set with an ID No. Turn OFF the other adjacent Cameras. (Unplug the AC adapters of those Cameras from the outlet.)
- Set the remote ID No. to the Camera. (See "6. OSD (On-Screen Display) on P.20) After setting, close the Menu screen by pressing ⑰ **MENU** button. Then, repeat the ID No. setting for all other Cameras in the same way.

(2) Operating the Cameras selectively

- Press ③ **ID** button, and the LED's of all adjacent Cameras will start blinking (at intervals of 0.4 sec). To cancel this, press ③ **ID** button again. Then, press ④ **1** through **9** buttons, and the LED's will go out, and selective operation by specifying the ID No. will be ready. Now, only the selected Camera can be operated via the wireless remote controller.

(3) Canceling the specific ID of the Cameras

- Hold down ③ **ID** button for over 2 sec, and the blinking LED on the Camera will light up. Then, unhand ③ **ID** button. Now, the selective operation has been cancelled, and all adjacent Cameras start operation via the wireless remote controller.
- Even if the Camera is rebooted, the selective operation by specifying the ID No. is cancelled.

6. SETTING IN THE OSD (ON-SCREEN DISPLAY) MENU

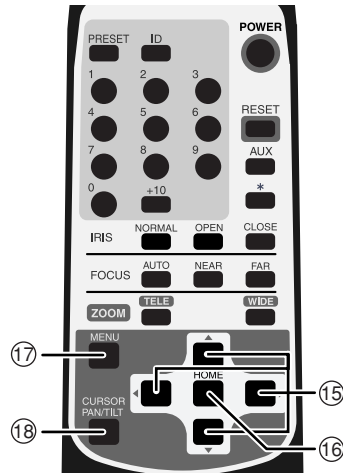

Each time ⑰ **MENU** button is pressed, the OSD menu is turned ON/OFF. In the hierarchical menu, when ⑰ **MENU** button is pressed, the screen immediately before appears.

In the OSD menu, ⑮ ▲ ▼ ◀ ▶ buttons and ⑯ **HOME** button are used for menu operation.

To suspend the menu operation and perform the PAN-TILT operation, press ⑱ **CURSOR/PAN-TILT** button.

To resume the menu operation, press ⑱ **CURSOR/PAN-TILT** button again.







● OSD menu

[1] MAIN CONTROL			
	Name	Function	Factory Settings
1	TITLE	To turn ON/OFF the character display in the bottom of the screen.	OFF
	SELECT	To select the title [CAMERA/PRESET] to be character-displayed (enabled only when the above [TITLE] is ON). [PRESET]: Preset position names 1 – 16 [CAMERA]: Camera main unit name.	CAMERA
2	SET INDICATE	To turn ON/OFF the screen display of the preset position upon its registration. The No. of the registered preset position is screen-displayed for seconds.	OFF
3	RS-485 ID	To set the ID addresses [1 – 223] for the RS-485 communication. Up to 223 Cameras can be controlled selectively.	1

[1] MAIN CONTROL			
	Name	Function	Factory Settings
4	RS-485 END	To turn ON/OFF the settings of the RS-485 terminating resistance contained in the Camera main unit. (For the telecommunication equipment to be connected to the RS-485 interface, a terminating resistance should be attached to both ends of the equipment having the longest route to prevent signal damping.)	OFF
5	REMOTE ID	To set the ID No. [1 – 9] for the Camera main unit for selective operation by using the wireless remote controller. When the ID No. is not to be set, input [0]. Up to 9 Cameras can be controlled selectively with one wireless remote controller.	0
6	OFF TIME	To set the time of the Low Power Consumption mode [OFF, 40min, 1h, 2h, 3h, 4h, 5h] If it has passed over this set time with no operation, the Camera power will be turned OFF automatically. (When ① [POWER] button is pressed again, the Camera power is turned ON again.)	OFF
7	AUTO RETURN	To set the time of automatic return to the home position [OFF, 30s, 1min, 2min, 5min, 10min, 20min, 30min] If it has passed over this set time with no operation after the PAN-TILT-ZOOM operation, the Camera will return automatically to the home position. The home position can be registered freely with the preset No. "0."	OFF
8	CAMERA2 PRESET	When this function is set to [ON], the setting of each item of [CAMERA2] can be registered in its preset position. (Set this button to [ON/OFF].)	OFF
[2] CAMERA1			
	Name	Function	Factory Settings
1	E-ZOOM MAX	To set the maximum magnification [OFF, ×1.5, ×2, ×2.5, ×3, ×4, ×6, ×8, ×16] When ⑬ [TELE] button on the wireless remote controller is held down, the optical zoom ×12 enters automatically from its end point into the digital zoom area.	OFF

[2] CAMERA1			
	Name	Function	Factory Settings
2	HS-SHUTTER	To select the high-speed shutter speed [OFF (1/60s), 1/100s, 1/250s, 1/500s, 1/1000s, 1/2000s, 1/4000s, 1/10000s, 1/20000s, 1/50000s]. When [LS-SHUTTER] is [ON], the shutter speed can be selected from [1/60sm 1/100s]. If the shimmer of fluorescent lamp is annoying when the shutter speed is set to [OFF (1/60s)], set the shutter speed to [1/100s], and the shimmer will be eased.	OFF
3	LS-SHUTTER	To set the low-speed shutter (electronic sensitivity up) to [ON/OFF]. When the object becomes dark, this function automatically varies the CCD storage time across several fields up to the set maximum level to optimize the brightness of the object.	OFF
	LS-MAX	To set the maximum number of fields of the low-speed shutter [2fields, 3fields, 4fields, 5fields, 6fields, 8fields, 12fields, 20fields, 40fields, 80fields]. If the CCD storage time is set longer, the image frame rate will decrease, and moving object could not be seen well.	4fields
	PRIORITY	To select the image attributes [MOTION (movement), COLOR (color), S/N (fineness)] to be prioritized when [LS-SHUTTER] is selected and the object becomes dark.	MOTION
4	ICR	To set the DAY/NIGHT function (IR cut filter removable function) When this function is set to [AUTO], the filter is attached/removed automatically according to the brightness. When the IR cut filter is removed, the color image is switched to B&W image.	OFF
5	AUTO LEVEL	To select the timing of switching from B&W to color [1 – 15]. Particularly when the infrared illumination is intensive, select larger numeric value to prevent hunting.	5
6	INFRARED	To set the infrared illumination using mode to [ON/OFF] To use the infrared illumination, set this function to [ON]. If the infrared illumination is used with this function in the [OFF] status, the image could be out of focus.	OFF
7	AGC GAIN	To set the maximum gain of the AGC [0dB, 4dB, 8dB, 16dB, 20dB, 24dB]. The AGC is a function of amplifying the signal from the CCD to make the object visible when the object becomes dark.	8dB

[3] CAMERA2												
	Name	Function	Factory Settings									
1	BLC	To set the backlight compensation function to [ON/OFF]. When there is an intensive light in the background, this function prevents the object from becoming dark.	OFF									
	BLC MODE	To select the Backlight Compensation Setting mode [AREA/HIST].	AREA									
	About the Backlight Compensation Setting mode											
	AREA	To select the image area of the object that needs an appropriate brightness and weighing according to the selected area.										
	HIST	To make the dark (blackened) part of the image visible regardless of the area.										
	AREA	To select the area [0 – 4] on the image where the backlight compensation function works when [AREA] is selected.	4									
		<table border="1" style="margin: auto;"> <tr> <td colspan="3">AREA0</td> </tr> <tr> <td>AREA3</td> <td>AREA4</td> <td>AREA2</td> </tr> <tr> <td colspan="3">AREA1</td> </tr> </table>	AREA0			AREA3	AREA4	AREA2	AREA1			
AREA0												
AREA3	AREA4	AREA2										
AREA1												
2	AP GAIN	To select the detail compensation level [-5 ~10]	±0									
3	WB	To select the White Balance Setting mode [ATW, AWC, INDOOR, OUTDOOR, FL-LIGHT, MWB].	ATW									
	About the White Balance Setting mode											
	ATW	To adjust the white balance by way of continuous, automatic following. (When the image is in monochrome all over, the white balance may not be matched.)										
	AWC	To adjust the white balance by one-push of button. When [AWC] is selected and  [HOME] button is pressed, the white balance is adjusted automatically in the then screen status. (This adjustment ends in seconds, and the adjusted value is fixed.)										

[3] CAMERA2			
Name		Function	Factory Settings
	INDOOR	This function is selected when the Camera is used indoors. The color temperature is assumed to be 3200K.	
	OUTDOOR	This function is selected when the Camera is used outdoors. The color temperature is assumed to be 6300K.	
	FL-LIGHT	This function is selected when the Camera is used with the fluorescent illumination ON. The color temperature is assumed to be 4200K.	
	MWB	To change the color tendency as desired.	
	MWB-R	To set the red color tendency [-30~+30] when [MWB] is selected.	±0
	MWB-B	To set the blue color tendency [-30~+30] when [MWB] is selected.	±0
[4] MASKING			
Name		Function	Factory Settings
1	MASK	To select [ON/OFF] of the masking function. When there is any part to be masked in the image to be picked up, this function masks such part. (However, during the PAN-TILT-ZOOM operation, mask is not displayed.) After setting the area data, even if [OFF] is selected and the mask display disappears, the area data will not be cleared.	OFF
	AREA1-6	To select [ON/OFF] of the masking for 6 areas, individually, when [ON] is selected in [MASK] When the area to be set is selected from [AREA1 – 6] and  button is pressed, the Detail Set window for the selected area appears.	
	About the detail setting of [AREA1 – 6]		
	SIZE	To set the mask size, display the [SIZE] Set window, move the size by using      buttons, and then press  button.	

[4] MASKING			
Name		Function	Factory Settings
	LOCATION	To set the mask position, display the [LOCATION] Set window, move the position by using ⑮ ▲▼◀▶ buttons, and then press ⑯ HOME button	
	SAVE	When the cursor is moved to [SAVE] and ⑯ HOME button is pressed, the mask data (position, size) is saved and enabled. However, when the rotation angle of TILT is 45° – 135° (±45° from the beneath-facing status of the Camera), the mask data cannot be saved.	
	CANCEL	When the cursor is moved to [CANCEL] and ⑯ HOME button is pressed, the unsaved mask is disabled, and the image returns to the status before the mask setting.	
	CLEAR	When the cursor is moved to [CLEAR] and ⑯ HOME button is pressed, the mask in display disappears, and the image falls into the status without the mask setting.	
<p>[Note] The masking function is not complete since it may make a part to be masked visible depending on the zoom position or Camera direction. Therefore, do not try to mask any confidential information by using this function.</p>			
[5] TITLE SET			
Name		Function	Factory Settings
1	CAMERA	To register the Camera main unit name. This function is convenient when multiple Cameras are used. Move the cursor to [CAMERA] to make the cursor blink. Go to the character to be set by using the ▶ button. Change the character by using the ▲▼ buttons, and move from character to character by using the ◀▶ buttons. By setting the characters one by one, up to 10 characters can be set. After setting, press ⑯ HOME button for saving.	CAMERA -1
2	PRESET1-16 HOME	To register all preset position names selectively. Move the cursor to [PRESET1 – 16] to make the cursor blink. Go to the character to be set by using the ▶ button. Change the character by using the ▲▼ buttons, and move from character to character by using the ◀▶ buttons. By setting the characters one by one, up to 10 characters can be set. After setting, press ⑯ HOME button for saving.	PRESET -1-16, HOME

[6] PAN TILT			
Name		Function	Factory Settings
1	MOTOR SPEED	To select the motor speed setting [AUTO/MANUAL] for the PAN-TILT operation. When [AUTO] is selected, the operation speed varies automatically according to the zoom position. When [MANUAL] is selected, the operation speed can be selected freely.	AUTO
	SPEED	To select the operation speed [0 – 7] (0: Fastest) when [MOTOR SPEED] is set to [MANUAL].	0
2	L/R DIRECTION	To change the direction of the PAN operation left and right.	OFF
3	DOVE COVER	When the Clear Dome Cover (PTC40CL) or the Smoke Dome Cover (PTC40SM), both available on option, is attached, set this function to [ON]. According to the dome cover, this function limits the TILT operation range. (When the dome cover is not attached, set this function to [OFF].)	OFF
4	PRESET STILL	When this function is set to [ON], the image during the movement between the preset positions becomes static (the image before the movement). In this mode, movement is enabled between the preset positions (including the home position), but the PAN-TILT-ZOOM operation is disabled. This function is useful to mask the images other than the home position image and the preset position images. (However, only when the ⑤ PRESET button is pressed, the image cannot be static.) (Set this function to [ON/OFF].)	OFF

[6] PAN TILT			
	Name	Function	Factory Settings
5	FLIP ANGLE	<p>When the rotation angle exceeds 90° (the Camera is facing beneath), the image reverses upside down. For example, the ceiling comes to the bottom of the image. In this case, this Camera automatically reverses the image vertically or horizontally.</p> <p>To select the image reverse angle [OFF, 100°, 110°, 120°, 130°, 140°] (When the image should not be reserved, set this function to [OFF].)</p>	120
[7] ALARM			
	Name	Function	Factory Settings
1	ALARM IN1	To set the preset position [PRESET1 – 16] for movement in case of input in the ALARM IN terminal <1>	PRESET1
	ALARM LOCK	When this function is set to [ON], as long as the input is in the ALARM IN terminal <1>, other operations are disabled. (Set this function to [ON/OFF].)	OFF
2	ALARM IN2	To set the preset position [PRESET1 – 16 AUTO] for movement in case of input in the ALARM IN terminal <2>.	PRESET2
3	ALARM OUT1	To select the signal time [OFF, 0.1s, 0.2s, 0.5s, 1s, 2s, 5s] to be outputted from the ALARM OUT terminal <1> in case of input in the ALARM IN terminal <1> or <2> and the completion of the preset operation.	0.1s
4	ALARM OUT2	<p>When this function is set to [ON], the ALARM OUT terminal <2> is enabled.</p> <p>When  [AUX] button is pressed (once), the alarm signal is outputted from the ALARM OUT terminal <2>.</p> <p>When this button is pressed again, this function is set to [OFF]. (Set this function to [ON/OFF].)</p>	OFF

7. SETTING OF ALARM IN-OUT

[1] Alarm Input

When each of the ALARM IN terminals <1> and <2> are short-circuited to the GND terminal, the Signal IN mode is established, and the Camera moves to the preset position set in the OSD menu beforehand.

- (1) Setting of the preset position for the ALARM IN terminals <1>, <2> (Refer to P. 27)
- (2) Lock mode when input is in the ALARM IN terminal <1> (Refer to P. 27)

[2] Alarm output

When input is made into either of the ALARM IN terminals <1> and <2> and the preset operation is completed, the alarm signal is outputted from the ALARM OUT terminal <1> for the time set in the OSD menu beforehand.

- (1) Setting the time for the ALARM OUT terminal <1> (Refer to P. 27)
- (2) Signal specifications for the ALARM OUT terminal <1>

Open collector output: Max. 12V, 30mA

When set so in the OSD menu, the signal output from the ALARM OUT terminal <2> (EXTERNAL OUT terminal) can be turned ON/OFF by pressing the ⑥ AUX button on the wireless remote controller.

- (3) Setting the time for ALARM OUT terminal <2> (Refer to P. 27)
- (4) Signal specifications for ALARM OUT terminal <2>

Open collector output: Max. 12V, 30mA

● ALARM IN-OUT terminal (6P connector (black))

Pin No.	Code Color	Terminal Name		Signaling System
①	Blue	ALARM IN1	IN <1>	No-voltage make contact
②	Purple	GND		—
③	Gray	ALARM IN2	IN <2>	No-voltage make contact
④	White	GND		—
⑤	Black	ALARM OUT1	OUT <1>	Open collector output
⑥	Pink	ALARM OUT2	OUT <2>	Open collector output

Note: When connecting with external equipment, observe the rated range.

8. SETTING OF RS-485

By wiring and connecting the RS-485 terminal of the 5P connector (white) with the RS-485 control, this Camera can be controlled.

By setting the ID address for the RS-485 communication in each Camera, up to 223 Cameras can be controlled by a single PC or controller.

To assure the reliability, connect DATA(+) and DATA(-) with a shielding twist pair wire.

To protect the Camera main unit and the controller, be sure to turn OFF all the equipment before starting connection.

● Transmission specifications

- Transmission mode : Synchronous half duplex
- Transmission speed : 9600bps
- Start bit : 1 bit
- Stop bit : 1 bit
- Parity bit : None

● RS-485 terminal (5P connector (white))

Pin No.	Code Color	Signal Name	Signal Function
①	Brown	DATA(+)	+ side: To input the transmitted/received data
②	Red	DATA(-)	- side: To input the transmitted/received data
③	Orange	DATA(+)	+ side: To output the transmitted/received data
④	Yellow	DATA(-)	- side: To output the transmitted/received data
⑤	Green	GND	GND

[1] Setting the terminating resistance (Refer to P. 21)

For the telecommunication equipment to be connected to the RS-485 interface, a terminating resistance should be attached to both ends of the equipment having the longest route to prevent signal damping.

Set the terminating resistance contained in the Camera to [ON/OFF] by selecting [MAIN CONTROL] – [RS-485END] in the OSD menu.

[2] Setting the ID address (Refer to P. 21)

Set the ID address for the RS-485 transmission to [1 – 223] by selecting [MAIN CONTROL] – [RS-485ID] in the OSD menu.

For the information of the data format specifications and command list, please contact our dealer.

9. SETTING OF VARIOUS MODES

[1] Initializing the settings

When the 4P DIP switch No. 2 located on the bottom of the main unit is set to [ON] and the Camera power is turned ON, the PAN-TILT settings, the lens settings, the preset settings, and the Camera settings made in the OSD menu are reset to the factory settings. Then, set the DIP switch No. 2 to [OFF].

Note: After initialization, be sure to set the DIP switch No. 2 to [OFF]. If it is left in [ON], each time the Camera power is turned ON, the settings will be initialized and cannot be saved.

Note: For the unused switches of the DIP switch, be sure to set to [OFF].

● Pin assignment

Pin No.	Normal	Operation	Function
1	OFF	Leave in OFF	—
2	OFF	ON → OFF	To initialize the settings
3	OFF	Leave in OFF	—
4	OFF	Leave in OFF	—

● 4P DIP switch

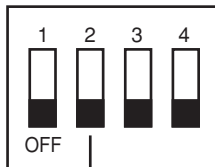

Setting Initialization mode

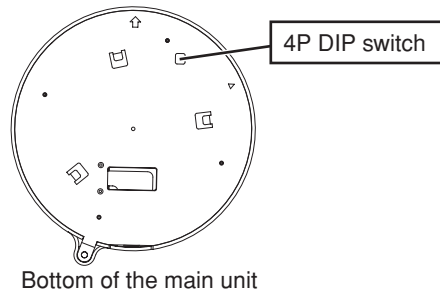

Bottom of the main unit

10. TROUBLESHOOTING HINTS

Symptom	Checking Point	Ref. Page
No image or dark image on the monitor	Is the Camera main unit connected correctly with the monitor with the video cable? Isn't the MONITOR IN terminal of the monitor wrong?	P. 13
	Is the DC IN cable connected correctly?	P. 13
	Isn't the DC IN cable or the video cable damaged? Isn't there any disconnection or incomplete contact?	P. 13
	Is the correct voltage (DC12V (DC11V-16V)) supplied to the outlet?	—
	Is the iris in proper position?	P. 16
	Isn't the zoom on the TELE side and imaging a dark, monochromatic object?	P. 15
	Isn't the LED lighting in red? If yes, the Camera power should be OFF.	P. 14
	Isn't the OFF TIME function activated, turning OFF the Camera power? (If the Camera power is turned ON without being aware of this and the no-operation status continues, the Camera power will be turned OFF again.)	P. 14, 21
	Is the high-speed shutter set?	P. 21
	Isn't the monitor TV system different from the signal of this Camera (NTSC)?	—
Out of auto focus	Isn't mode the Manual Setting mode? If yes, press the AUTO button to return the mode to the Auto Focus mode.	P. 16
	Isn't a flat or fast-moving object shot? (Some objects are not suitable for the Auto Focus.)	P. 16
	Isn't the infrared illumination intensive? Set [CAMERA1] – [INFRARED] to [ON] in the OSD menu.	P. 22

Symptom	Checking Point	Ref. Page
No operation via wireless remote controller	Isn't wrong ID number set?	P. 19
	Check the remaining battery power of the wireless remote controller.	P. 7
	If the sunlight or the fluorescent lamp light of the inverter enters the infrared sensor, the signal from the wireless remote controller could not be sensed normally. If yes, block the light, and then operate the wireless remote controller.	P. 28
	Isn't the 4P DIP switch No. 1 located on the bottom of the main unit set to [ON]? If yes, the wireless remote controller cannot be operated.	P. 30
	Isn't [PAN TILT] – [PRESET STILL] set to [ON] in the OSD menu? If yes, the PAN-TILT-ZOOM operation is disabled.	P. 26
B&W image	This Camera has the B&W/color switching function. Check the settings.	P. 22
No switching to B&W image	Isn't [CAMERA1] – [ICR] set to [OFF] in the OSD menu? If yes, the DAY/NIGHT function is disabled.	P. 22
Frequent color/B&W screen	Isn't the infrared illumination intensive? Increase the numeric of [CAMERA1] – [AUTO LEVEL] in the OSD menu.	P. 22
Shimmer when imaging fluorescent	When [CAMERA1] – [HS-SHUTTER] is set to [OFF] in the OSD menu, the shimmer will be eased by setting the shutter speed to [1/100s]. (However, since this will change the brightness, the iris operation may be required.)	P. 22
No adjustment of preset position	The Camera head direction may have been changed by hand. Correct the position by pressing the RESET button on the wireless remote controller.	P. 17

If the problem still remains after checking the above and apply the remedy, consult our dealer from whom you have purchased the Camera or our branch office or sales office nearest to you.

11. SPECIFICATIONS

● General

Item	Specifications		
Power source	DC12V (DC11V-16V)		
Current consumption	MAX. 1A		
Outside dimensions	Diameter 139mm (5.74in.), Height 121mm (4.76in.) (Projections and fitting plate not included)		
Weight / mass	1.98lb (Fitting plate included)		
Television system	NTSC system		
Video signal output terminal	Composite video	BNC jack / 75Ω unbalanced	1
External control terminal	RS-485	5P connector (white)	1
	ALARM IN-OUT	6P connector (black)	1

● Lens

Item	Specifications
Optical zoom	Powered 12 times
Focal length	F = 3.8 – 45.6mm
F No.	F1.6 – 2.7
Field of view (horizontal)	4.5° – 52.8°
Iris	Auto (level adjustable)
Focus adjustment	Full-auto / Manual

● PAN-TILT

Item	Specifications
PAN range	Left 175°, Right 175°
TILT range	Up 15°, Down 195°
PAN-TILT speed	Auto / Manual (8 speeds)
Preset point	16 points
Auto return to home position	Provided
Pan / Tilt movable range limit	Provided (Setting enabled when dome cover is mounted)

● Camera

Item	Specifications
Image pickup element	1/4-in CCD
Effective picture element	768 (Horizontal) × 494 (Vertical)
Total picture element	811 (Horizontal) × 508 (Vertical) (410,000 pixels)
Minimum illumination	Color: 1 lx (DAY/NIGHT function OFF, 30IRE) B&W: 0.3 lx (DAY/NIGHT function ON, 30IRE)
Digital zoom	Max. 16 times
Backlight compensation	ON/OFF
White balance	Auto / One-push / Manual / Indoor mode / /Outdoor mode / Fluorescent lamp mode
Sync. system	Internal synchronization
Resolution	Horizontal: 470 TV lines or more Vertical: 360 TV lines or more
S/N ratio	49dB
DAY/NIGHT function	Provided
Masking function	Provided
Image flip (vertical, horizontal) function	Provided
AGC gain adjustment	Provided
Detail compensation level adjustment	Provided
High-speed shutter	Provided (1/60s – 1/50000s)
Low-speed shutter (Electronic sensitivity up)	Provided (Max. 80 fields)

Note: Measured in flat lamp light. The numeric value depends on the light source.

● Others

Item	Specifications
OSD Menu window	Provided (Camera setting)
Daisy chain connection (RS-485)	Max. 223 Cameras

12. SUPPLIED ACCESSORIES

Name	Quantity
Wireless remote controller (RC-PTY)	1
Battery size AAA	2
RS-485, Relay cable (5P connector color: White)	1
ALARM IN-OUT, Relay cable (6P connector color: Black)	1
Ceiling plate	1
Main unit set screw M3 × 5	1
Fixing plate (for under the roof)	1
Fixing screw M4 × 40	4
Instruction Manual	1

Note: Weight and dimensions are approximate.

Note: Design and specification are subject to change without notice.

13. OPTIONS

Name
Clear dome cover PTC40CL
Smoke dome cover PTC40SM

Note: The specifications are subject to change without notice.

~~ELMO~~ is a trademark of ELMO CO., LTD.

WARNING:

■ Unauthorized recording of copyrighted, materials, photographs, etc. may infringe on the rights of copyright owners and be contrary to copyright laws.

ELMO CO., LTD.

6-14, Meizen-cho, Mizuho-ku,
Nagoya, 467-8567, Japan

OVERSEAS SUBSIDIARY COMPANIES

U.S.A**ELMO USA CORP.**

1478 Old Country Road, Plainview, NY 11803-5034

Tel:(516)501-1400 Fax:(516)501-0429

E-mail:elmo@elmousa.com

Web : <http://www.elmousa.com>

Canada**ELMO CANADA CORP.**

44 West Drive, Brampton, Ontario L6T 3T6

Tel:(905)453-7880 Fax:(905)453-2391

E-mail : info@elmocanada.com

Web : <http://www.elmocanada.com>

Germany**ELMO (Europe) G.m.b.H**

Neanderstr. 18, 40233 Düsseldorf

Tel:(0211)3864-70 Fax:(0211)376630

E-mail : info@elmoeurope.com

Web : <http://www.elmoeurope.com>

Printed in Japan
6X1PTYC02